

Conduit Box and parts for connecting to Conext XW+ inverter/charger and PDP

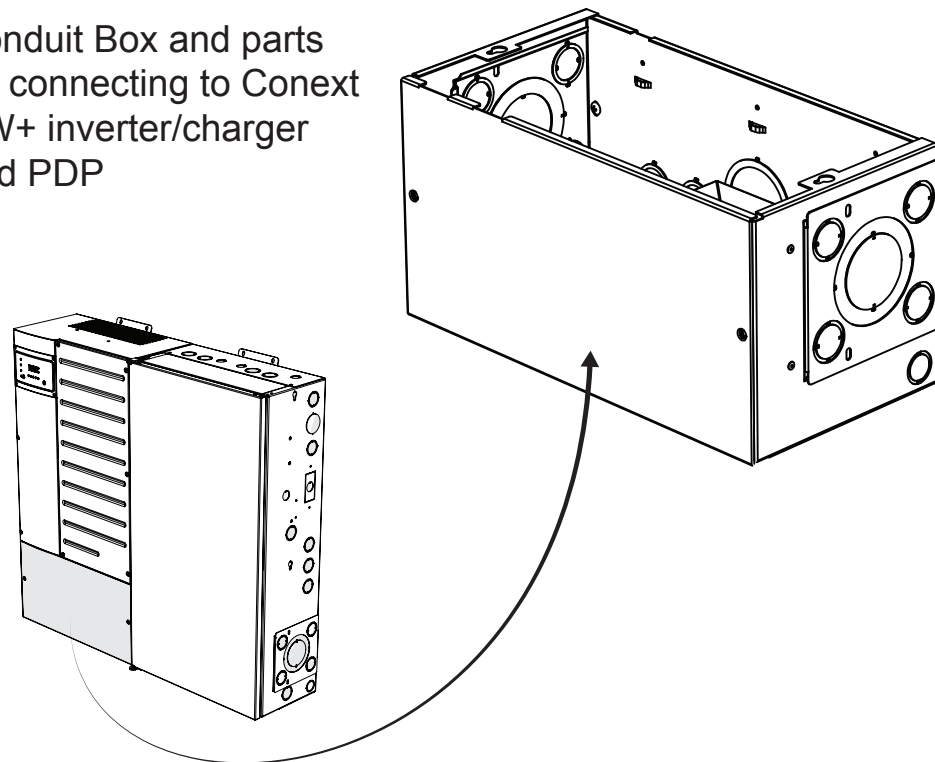

A Important Safety Information

This Guide is intended for anyone who needs to operate, configure, and troubleshoot the Conext XW+ Inverter/Charger. Certain configuration tasks should only be performed by qualified personnel in consultation with your local utility and/or an authorized dealer. Electrical equipment should be installed, operated, serviced, and maintained only by qualified personnel. Servicing of batteries must only be performed or supervised by qualified personnel with knowledge of batteries and their required precautions.

Qualified personnel have training, knowledge, and experience in:

- Installing electrical equipment
- Applying applicable installation codes
- Analyzing and reducing the hazards involved in performing electrical work
- Installing and configuring batteries
- Selecting and using Personal Protective Equipment (PPE)

No responsibility is assumed by Schneider Electric for any consequences arising out of the use of this material.

1. **Before using the inverter, read all instructions and cautionary markings on the unit, the batteries, and all appropriate sections of this manual.**
2. Use of accessories not recommended or sold by the manufacturer may result in a risk of fire, electric shock, or injury to persons.
3. The inverter is designed to be permanently connected to your AC and DC electrical systems. The manufacturer recommends that all wiring be done by a certified technician or electrician to ensure adherence to the local and national electrical codes applicable in your jurisdiction.
4. To avoid a risk of fire and electric shock, make sure that existing wiring is in good condition and that wire is not undersized. Do not operate the inverter with damaged or substandard wiring.
5. Do not operate the inverter if it has been damaged in any way.
6. This unit does not have any user-serviceable parts. Do not disassemble the inverter except where noted for connecting wiring and cabling. See your warranty for instructions on obtaining service. Attempting to service the unit yourself may result in a risk of electrical shock or fire. Internal capacitors remain charged after all power is disconnected.
7. To reduce the risk of electrical shock, disconnect both AC and DC power from the inverter before attempting any maintenance or cleaning or working on any components connected to the inverter. Putting the unit in Standby mode will not reduce this risk.
8. The inverter must be provided with an equipment-grounding conductor connected to the AC input ground.
9. Do not expose this unit to rain, snow, or liquids of any type. This product is designed for indoor use only. Damp environments will significantly shorten the life of this product and corrosion caused by dampness will not be covered by the product warranty.
10. To reduce the chance of short-circuits, always use insulated tools when installing or working with this equipment.
11. Remove personal metal items such as rings, bracelets, necklaces, and watches when working with electrical equipment.

B Materials List

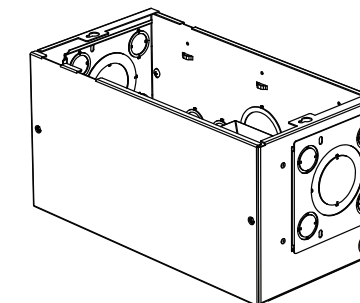

Conduit Box for attaching to the bottom of a Conext XW+ inverter/charger.



Bushings for AC wiring knockouts and AC Sync and Xanbus knockouts

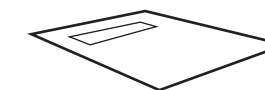

Warning label

Installer Provided Tools and Materials:

- Phillips head screwdriver
- Screws for wall mounting

A Important Safety Information

Read and Save These Instructions - Do Not Discard

This guide contains important safety instructions for the Conext XW+ Inverter/Charger that must be followed during installation procedures. Read and keep this Installation Guide for future reference.

Read these instructions carefully and look at the equipment to become familiar with the device before trying to install, operate, service or maintain it. The following special messages may appear throughout this bulletin or on the equipment to warn of potential hazards or to call attention to information that clarifies or simplifies a procedure.

 The addition of either symbol to a "Danger" or "Warning" safety label indicates that an electrical hazard exists which will result in personal injury if the instructions are not followed.

 This is the safety alert symbol. It is used to alert you to potential personal injury hazards. Obey all safety messages that follow this symbol to avoid possible injury or death.

DANGER

DANGER indicates a hazardous situation which, if not avoided, will result in death or serious injury.

WARNING

WARNING indicates a hazardous situation which, if not avoided, could result in death or serious injury.

CAUTION

CAUTION indicates a hazardous situation which, if not avoided, could result in minor or moderate injury.

NOTICE

NOTICE is used to address practices not related to physical injury.. The safety alert symbol shall not be used with this signal word.

DANGER

HAZARD OF ELECTRIC SHOCK, EXPLOSION, OR ARC FLASH

- Apply appropriate personal protective equipment (PPE) and follow safe electrical work practices. See NFPA 70E or CSA Z462.
- This equipment must only be installed and serviced by qualified electrical personnel.
- Never operate energized with covers removed
- Energized from multiple sources. Before removing covers identify all sources, de-energize, lock-out, and tag-out and wait 2 minutes for circuits to discharge
- Always use a properly rated voltage sensing device to confirm all circuits are de-energized.

Failure to follow these instructions will result in death or serious injury.

HAZARD OF ELECTRIC SHOCK, EXPLOSION, OR ARC FLASH

Batteries can present a risk of electric shock and high short-circuit current. The following precautions must be observed when working with batteries:

- Remove watches, rings or other metal objects.
- Use tools with insulated handles.
- Wear protective glasses, gloves and boots.
- Do not lay tools or other metal parts on top of batteries.
- Disconnect the charging source prior to connecting or disconnecting battery terminals.

Failure to follow these instructions will result in death or serious injury.

HAZARD OF ELECTRIC SHOCK, EXPLOSION, OR ARC FLASH

- Battery Circuit Breakers must be installed according to the specifications and requirements specified by Schneider Electric.
- Servicing of batteries must only be performed by qualified personnel and the required precautions. Keep unqualified personnel away from batteries.

Failure to follow these instructions will result in death or serious injury.

Contact Information

www.schneider-electric.com

Please contact your local Schneider Electric Sales Representative or visit the Schneider Electric website at: <http://www.SEsolar.com>

Exclusion for Documentation

UNLESS SPECIFICALLY AGREED TO IN WRITING, SELLER

- (A) MAKES NO WARRANTY AS TO THE ACCURACY, SUFFICIENCY OR SUITABILITY OF ANY TECHNICAL OR OTHER INFORMATION PROVIDED IN ITS MANUALS OR OTHER DOCUMENTATION;
- (B) ASSUMES NO RESPONSIBILITY OR LIABILITY FOR LOSSES, DAMAGES, COSTS, OR EXPENSES, WHETHER SPECIAL, DIRECT, INDIRECT, CONSEQUENTIAL OR INCIDENTAL, WHICH MIGHT ARISE OUT OF THE USE OF SUCH INFORMATION. THE USE OF ANY SUCH INFORMATION WILL BE ENTIRELY AT THE USER'S RISK, AND
- (C) REMINDS YOU THAT IF THIS MANUAL IS IN ANY LANGUAGE OTHER THAN ENGLISH, ALTHOUGH STEPS HAVE BEEN TAKEN TO MAINTAIN THE ACCURACY OF THE TRANSLATION, THE ACCURACY CANNOT BE GUARANTEED, APPROVED CONTENT IS CONTAINED WITH THE ENGLISH LANGUAGE VERSION WHICH IS POSTED AT WWW.SCHNEIDER-ELECTRIC.COM.

C Knockout Dimensions

NOTICE

EQUIPMENT DAMAGE

Do not drill, cut or punch holes into the Conduit Box, XW+ chassis, or Power Distribution Panel. Use only the knockouts provided for conduit entry.

Failure to follow these instructions can result in damage to equipment.

When removing your choice of knockouts, ensure no debris remains inside the chassis. Insert appropriately-sized conduit bushings.

Remove interior screw to remove the left or right sideplate

Horizontal raceway for routing Xanbus, AC Sync, Aux, and BTS cabling between inverters or outside the unit

V-raceway for routing Xanbus, AC Sync, Aux, and BTS cabling to data ports on the bottom of the inverter

Side Knockouts

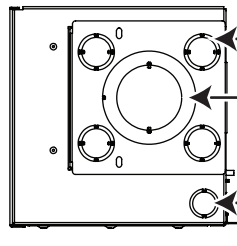

Inner: 3/4" trade (28.2 mm or PG21)
Outer: 1" trade (35.0 mm)

Inner: 2" trade (62.7 mm)
Outer: 3" trade (90.0 mm)

Inner: 1/2" trade (22.2 mm or PG16)
Outer: 3/4" trade (28.0 mm)

Back Knockouts

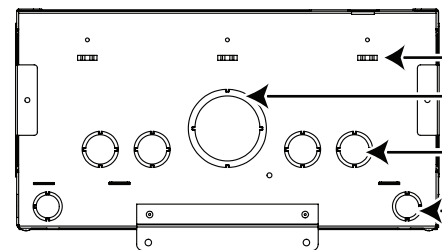

Fits up to 8 mm wide cable ties

Inner: 2" Trade (62.7 mm)
Outer: 2 1/2" Trade (75.6 mm)

Inner: (22.2 mm or PG21)
Outer: (28.2 mm)

Inner: 1/2" trade (22.2 mm or PG16)
Outer: 3/4" trade (28.0 mm)

Bottom Knockouts

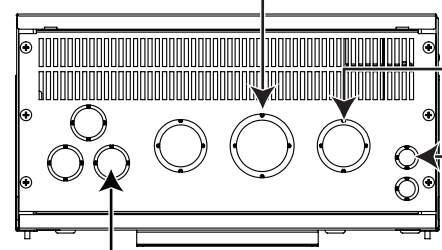

Inner: 1 1/2" Trade
Outer: 2" Trade

Inner: ISO-40
Outer: ISO-50

Inner: ISO-16
Outer: 1/2" Trade (PG 16)

Inner: 3/4" Trade (PG 21)
Outer: 1" Trade

D Wall Mounting the Conduit Box

Wall Mounting Considerations

- If conduit is routed from the floor, remove the bottom panel of the Conduit Box before wiring. Remove the appropriate knockouts and re-attach the bottom panel once to proceed with conduit installation and wiring.
- If conduit is routed through the wall on which the XW+ unit and PDP are mounted, remove the appropriate knockouts on the back panel of the Conduit Box.
- Use plastic cable ties for cable management inside the Conduit Box.

1 Wall mount the Conext XW+

IMPORTANT: Before installing the Conduit Box, wall mount the Conext XW+.

For detailed mounting instructions, see the *Conext XW+ Inverter/Charger Installation Guide*.

2 Remove the Conduit Box front panel, the left or right sideplate and the raceway knockout

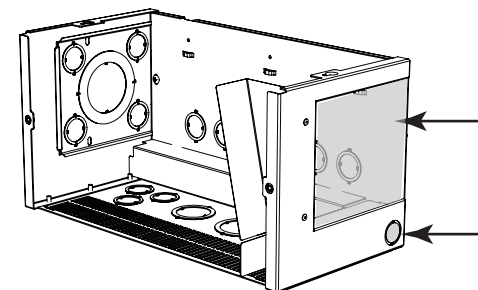

Remove sideplate and raceway knockout

Either sideplate can be removed depending on the location of the adjacent PDP and Conext XW+. If the Conduit Box is located between two XW+ units, then remove both sideplates and knockouts.

3 Secure the Conduit Box to the Conext XW+

1. Align the keyhole slots on the top edge of the Conduit Box with the corresponding screws on the bottom of the inverter. Loosen the screws if necessary.
2. Hang the Conduit Box on the XW+ unit by fitting the keyholes to the screws and pushing towards the wall until snug.

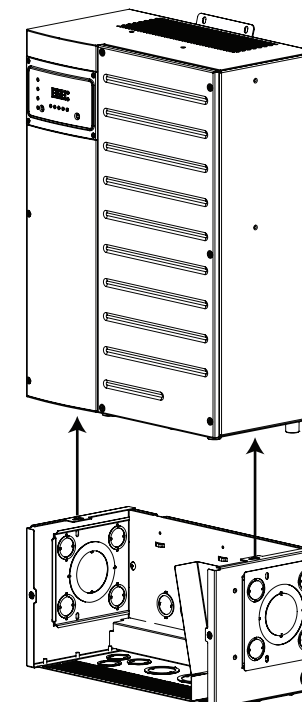

4 Secure the Conduit Box to the wall

Using two screws suitable for the mounting surface (not provided), secure the bracket at the bottom edge of the rear panel to the wall.

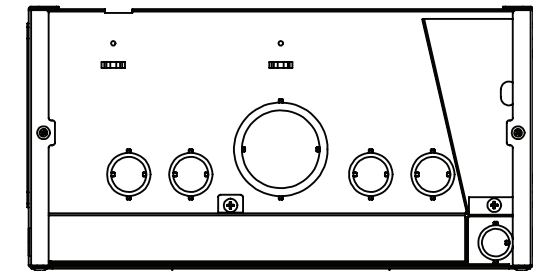

Secure the bracket with wall screws (not provided)

E Wiring the AC, DC, and Network Cable Connections

Route the AC, DC and Xanbus network wiring through the Conduit Box.

For detailed instructions and wiring diagrams, see the *Conext XW+ Inverter/Charger Installation Guide*.

F Secure the Front Panel of the Conduit Box

Re-attach the front panel of the Conduit Box when the wiring is complete

1. Slide the bottom lip of the front panel over the lower edge of the rear panel.
2. Align the two holes in the front panel with the two holes in the back panel.
3. Using two #10-16x3/8" tapping screws (provided), secure the front panel to the rear panel as shown.

